

Typical Features

- ◆ Wide input voltage range 85-305VAC/120-430VDC
- ◆ No load power consumption $\leq 0.2W@220VAC$
- ◆ Efficiency up to 80%(Typ.)
- ◆ Operating temperature from $-40^{\circ}C$ to $+75^{\circ}C$
- ◆ Switching Frequency 65KHz
- ◆ Short circuit & over current protections
- ◆ Isolation voltage 3000VAC
- ◆ Altitude during operating 4000m Max
- ◆ Compliant with IEC/EN62368/UL62368
- ◆ PCB SIP mounting

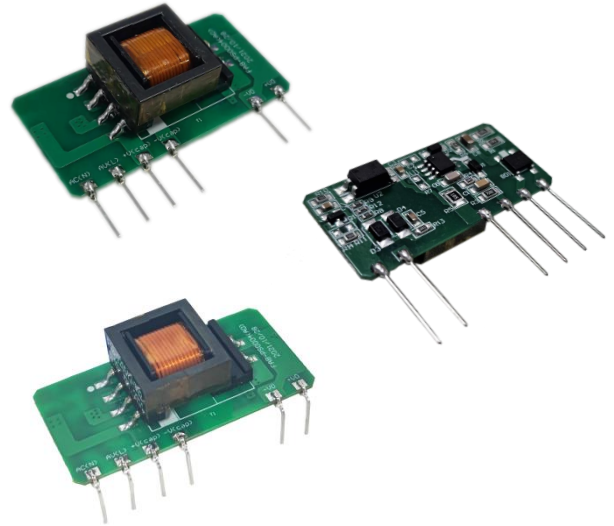

Application Field

The **FA8-220SXXB9N3** series from Aipu is a compact, high-efficiency open-frame power module. It features a universal input voltage range (accepting both AC and DC inputs), low ripple, low temperature rise, low power consumption, high reliability, robust safety isolation, and excellent EMC performance. Its EMC and safety specifications comply with international EN55032 and IEC/EN61000 standards. This series is widely used in electric power systems, industrial applications, instrumentation, and smart homes. For applications in harsh EMC environments, please refer to our recommended application circuits.

Typical Product List

Certificate	Part No.	Input Voltage Range		Output Specifications			Max Capacitive Load @220VAC (uF)	Ripple & Noise 20MHz (Max) (mVp-p)	Efficiency @full load 220VAC (Typ.) (%)
		Nominal (VAC)	Range (VAC)	Power P(W)	Voltage Vo (VDC)	Current Io(mA)			
		-	FA8-220S05B9N3(-1)	220	85 - 305	8			
-	FA8-220S12B9N3(-1)	12	667				3000	100	80
-	FA8-220S24B9N3(-1)	24	333				1000	120	82

Note 1: The typical value of efficiency is based on the product tested after half an hour burn-in at full load.

Note 2: The full load efficiency should be in $\pm 2\%$ of the typical value in this table. The efficiency is calculated by the way that the full output power is divided by the input power.

Note 3: Please contact Aipu sales for other output voltages requirements of this series but not listed in this table.

Note 4: The part number suffix -1 indicates the part with pins 90° bent.

Input Specifications

Item	Test Condition	Min	Typ.	Max	Unit
Input voltage range	AC input	85	220	305	VAC
	DC input	120	310	430	VDC
Input frequency	-	47	50	63	Hz
Input current	115VAC input	-	-	0.20	A

	220VAC input	-	-	0.2	
Surge current	115VAC input	-	-	10	A
	220VAC input	-	-	20	
Standby power consumption	115VAC input	-	-	0.2	W
	220VAC input	-	-		
Leakage current	-	0.5mA TYP/ 230VAC/ 50Hz			
Recommended external fuse	-	2A/300VAC Slow-blow fuse			
Hot-plug	-	N/A			
ON/OFF Control	-	N/A			

Output Specifications						
Item		Test Condition	Min	Typ.	Max	Unit
Output voltage accuracy		Full input voltage range, any load	-	±2.0	±3.0	%
Line regulation		Rated load	-	-	±0.5	%
Load regulation		Nominal input voltage, 20%~100% load	-	-	±1.0	%
Minimum load		Single Output	0	-	-	%
Temperature drift coefficient		-	-	-	±0.03	%/°C
Turn-on delay time		Input 115VAC (full load)	-	-	1000	mS
		Input 220VAC (full load)	-	-		
Power-off hold up time		Input 115VAC (full load)	-	50	-	mS
		Input 220VAC (full load)	-	80	-	
Dynamic response	Overshoot range	25%~50%~25%	-5.0	-	+5.0	%
	Recovery time	50%~75%~50%	-	-	+5.0	mS
Output start-up overshoot		Full input voltage range	≤10			%Vo
Short circuit protection			Continuous, self-recovery			Hiccup
Over current protection		Input 220VAC	120%Io	-	230%Io	mA
Ripple & Noise		Full input voltage range, 20MHz bandwidth	-	-	120	mVp-p

Note: Ripple and noise are measured using the parallel cable method. Please refer to the "Ripple & Noise Test Instructions" below for detailed methodology and setup..

General Specifications						
Item		Test Condition	Min	Typ.	Max	Unit
Switching frequency			-	65	-	KHz
Operating temperature		Refer to the Temperature Derating Graph	-40	-	+75	°C
Storage temperature			-40	-	+105	
Soldering temperature		Wave soldering	260±4°C, time 5-10S			
		Manual soldering	360±8°C, time 4-7S			
Relative humidity			10	-	90	%RH
Isolation voltage	I/P-O/P	Test 1min, leakage current <5mA	3000	-	-	VAC
Insulation resistance	I/P-O/P	@ DC500V	100	-	-	MΩ

MTBF	MIL-HDBK-217F@25°C	300	-	-	K hours
Safety standard		IEC/EN62368			
Vibration		10-55Hz, 10G, 30 Min, along X, Y, Z			
Safety standard		CLASS II			
Weights & Dimensions	Part No.	Weight (Typ.)	Dimensions L x W x H		
	FA8-220SXXB9N3(-1)	10g	44.50X22.00X15.00 mm	1.752X0.866X0.590 inch	

EMC Performance

Items		Test Standard	Performance/Class
EMC	EMI	CE	CISPR32/EN55032 CLASS B (with the Recommended Circuit 2)
		RE	CISPR32/EN55032 CLASS B (with the Recommended Circuit 2)
	EMS	RS	IEC/EN61000-4-3 10V/m Perf. Criteria B (with the Recommended Circuit 1)
		CS	IEC/EN61000-4-6 3Vr.m.s Perf. Criteria B (with the Recommended Circuit 1)
		ESD	IEC/EN61000-4-2 Contact ±6KV / Air ±8KV Perf. Criteria B
		Surge	IEC/EN61000-4-5 Line to line ±1KV Perf. Criteria B
		EFT	IEC/EN61000-4-4 ±2KV Perf. Criteria B
		Voltage dips & Interruptions	IEC/EN61000-4-11 0%~70% Perf. Criteria B

Product Characteristics Graphs

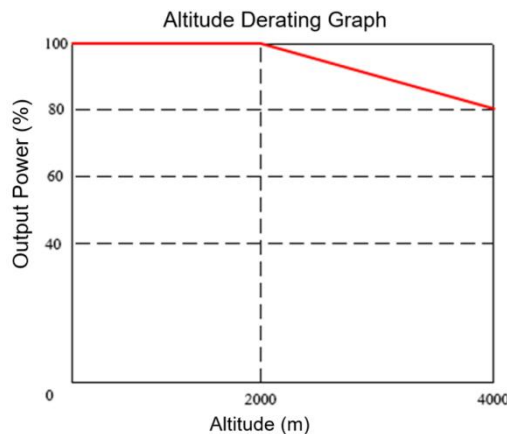
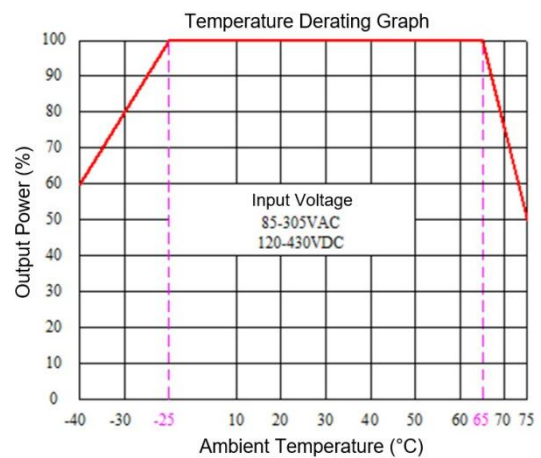
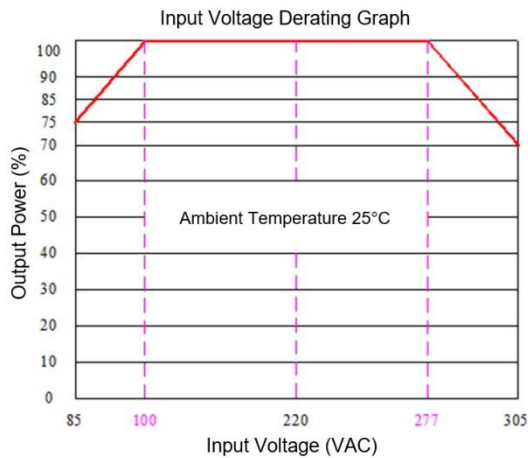

Note 1: For input voltages of 85-100VAC, 277-305VAC, 120-140VDC, or 390-430VDC, temperature derating must be applied

based on the input voltage derating curve.

Note 2: This product is designed for natural convection cooling. Please contact us if it will be used in an enclosed environment.

Typical Application Circuit and Recommended EMC Parameters

1. Typical application circuit diagram

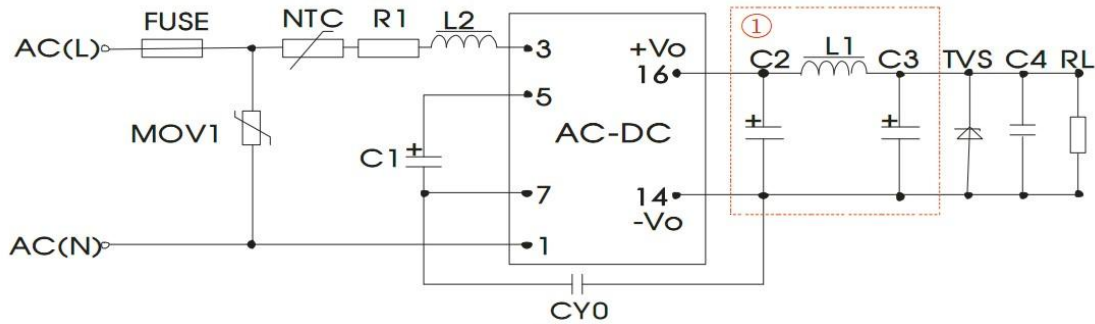

Figure - Circuit 1 (① is a Pi type filtering circuit)

Part No.	C1 (*)	C2(*) Solid-state capacitor	L1 (*)	C3(*) Electrolytic capacitor	C4	L2	NTC	CY0	FUSE (*)	TVS
FA8-220S05B9N3	22μF/ 450V	470μF/16V	2.0uH	220μF/16V	0.1μF 50V	4.7mH	5D-9	Y1 102M 400V	2A/300V Slow-blow fuse	SMBJ7.0A
FA8-220S12B9N3		220μF/16V		100μF/16V						SMBJ20A
FA8-220S24B9N3		220μF/35V		100μF/35V						SMBJ30A

Note:

- C1: For AC input, C1 is an input filter electrolytic capacitor (required). The recommended value is 22uF/450V. For DC input, C1 acts as a bulk filter capacitor in the EMC filter (required). The recommended value is 22uF/450V.
- R1: Wire-wound resistor. The recommended value is 12 ohms, 5W.
- MOV1: Varistor. The recommended model is 10D561K/3500A.

2. Recommended EMC circuit diagram (for higher EMC requirement)

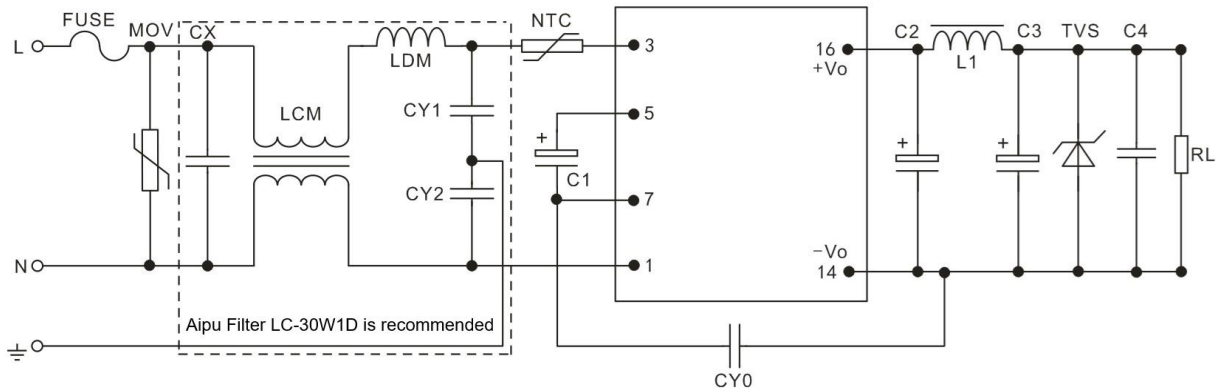
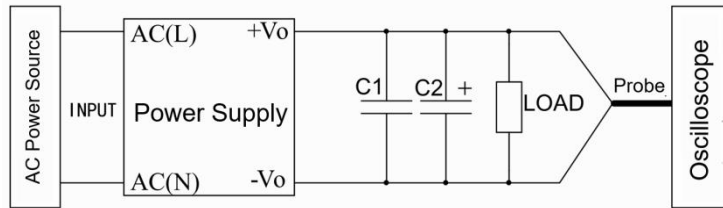

Figure - Circuit 2

FUSE	2.0A/300VAC Time-delay fuse (Required)	NTC	5D-9
MOV	10D561K/3500A	CY1, CY2	Y1/102M/400VAC
CX	X2/224K/310VAC	LDM	330μH/0.3A
LCM	40mH Min/0.3A		

Ripple & Noise Test Instructions (Parallel Cable Method, 20MHz Bandwidth)



1. Ripple and noise are measured using the parallel cable method with the oscilloscope bandwidth limited to 20MHz. Remove the oscilloscope probe cap and ground clip, and connect C1 (0.1uF ceramic capacitor) and C2 (10uF high-frequency low-ESR electrolytic capacitor) in parallel at the probe tip. Set the oscilloscope sampling mode to Sample.
2. Output ripple and noise test setup: Connect the module input to the power supply and the output to the electronic load via a fixture board. Use separate sampling wires directly from the output ports for measurement. Select insulated power cables with an appropriate wire gauge based on the output current.

Mechanical Dimensions

Third Angle Projection

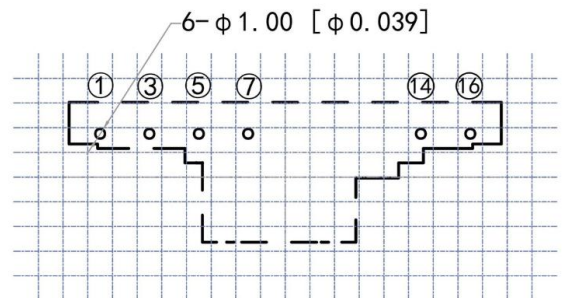
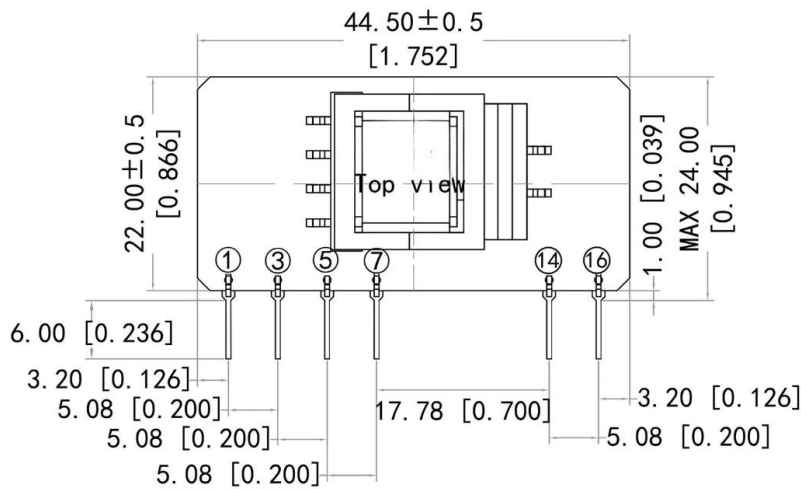

Unit: mm[inch]
General tolerance: $\pm 0.5[\pm 0.020]$
Pin size SQ 0.5x0.5 $\pm 0.05[0.02 \times 0.02 \pm 0.002]$

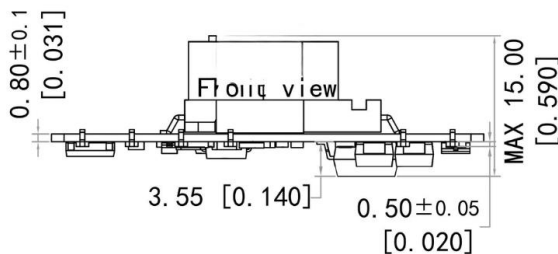

Unit: mm[inch]
Printed Board Vertical View
Lattice Spacing: 2.54mm(0.1 inch)
General tolerance: $\pm 0.5\text{mm}[\pm 0.020 \text{ inch}]$
Pin size SQ 0.5x0.5 $\pm 0.05\text{mm}[0.02 \times 0.02 \pm 0.002 \text{ inch}]$

Pin-out Function Description						
Pin No.	1	3	5	7	14	16
Symbol	AC(N)	AC(L)	+Vc	-Vc	-Vo	+Vo
Description	AC Input (Neutral)	AC Input (Line)	Capacitor Positive	Capacitor Negative	Output Negative	Output Positive

(-1) Mechanical Dimensions

Third Angle Projection

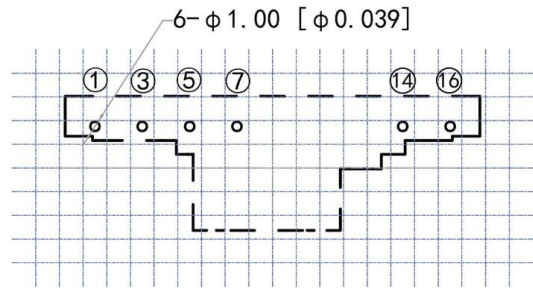
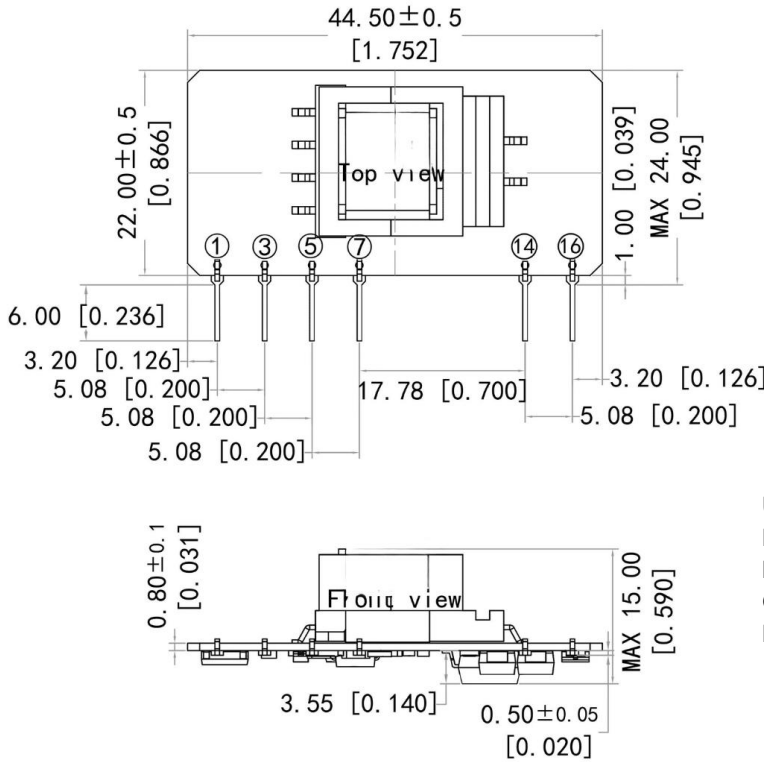

Unit: mm[inch]
 Printed Board Vertical View
 Lattice Spacing: 2.54mm(0.1 inch)
 General tolerance: $\pm 0.5\text{mm}$ [± 0.020 inch]
 Pin size SQ 0.5x0.5 $\pm 0.05\text{mm}$ [$0.02 \times 0.02 \pm 0.002$ inch]

Pin-out Function Description

Pin No.	1	3	5	7	14	16
Symbol	AC(N)	AC(L)	+Vc	-Vc	-Vo	+Vo
Description	AC Input (Neutral)	AC Input (Line)	Capacitor Positive	Capacitor Negative	Output Negative	Output Positive

Application Notice

1. The product should be used according to the specifications, otherwise it could be permanently damaged.
2. The product performance cannot be guaranteed if it works at a lower load than the minimum load defined.
3. The product performance cannot be guaranteed if it works under over-load condition.
4. Unless otherwise specified, all values or indicators on this datasheet are tested at $T_a=25^\circ\text{C}$, humidity < 75%RH, nominal input voltage and rated load (pure resistance load).
5. All values or indicators on this datasheet have been tested based on Aipupower test specifications.
6. The performance specifications listed above apply to the standard models in this manual. Specifications for non-standard or custom models may vary. For specific details, please contact our technical support team directly.
7. Aipupower can provide customization service.

Guangzhou Aipu Electron Technology Co., Ltd

Address: Building 4, HEDY Park, No.63, Punan Road, Huangpu Dist, Guangzhou, China.

Tel: 86-20-84206763 Fax: 86-20-84206762 HOTLINE: 400-889-8821

E-mail: sales@aipu-elec.com Website: <https://www.aipupower.com>